

# Selection Form

Rotating Machine (Cylindrical Object)

Requested Date:

Please check "✓" the corresponding item in . If you are unable to make a selection, please leave it blank.

## Select Series and Backlash of High Precision Reducer for Servo Motor

- Series →  Compact Parallel Shaft • Planetary Type (APG)     Compact Hollow Shaft Type (AFC)     Compact Solid Shaft Type (AFC)
- Backlash →  3 arcmin  15 arcmin     3 arcmin  30 arcmin     3 arcmin  30 arcmin
- Series →  Hollow Shaft Type (AF3)     Solid Shaft Type (AF3)     Parallel Shaft Type (AG3)     Right Angle Shaft (AH2)
- Backlash →  1 arcmin  3 arcmin     1 arcmin  3 arcmin     Low Backlash     Low Backlash
- Requested Model (    ) \* Low Backlash (30 to 60 arcmin) accuracy would be different by reduction ratio.
- \* If you already know the model number, please enter that in (    ).

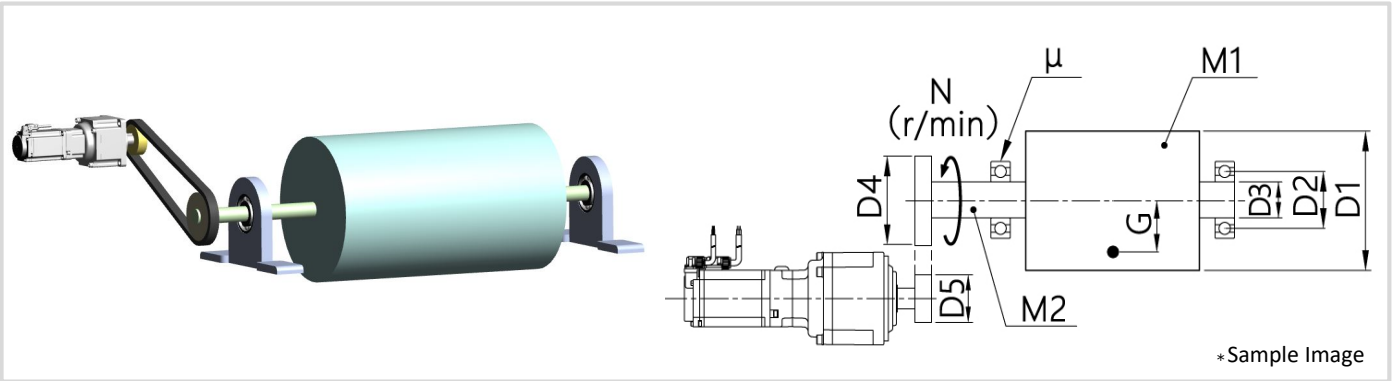

## User Condition

- Rotational Speed of the Work    N =  r/min
- Weight of the Work    M1 =  kg
- Weight of the Rotating Shaft    M2 =  kg
- Outer Diameter of the Work    D1 =  mm
- Pitch Circle Diameter of the Rolling Element Bearing    D2 =  mm
- Outer Diameter of the Rotating Shaft    D3 =  mm
- P.C.D. of Driven Side Sprocket (Timing Pulley, Gear) \* Not required for direct coupling    D4 =  mm
- P.C.D. of Drive Side Sprocket (Timing Pulley, Gear) \* Not required for direct coupling    D5 =  mm
- Gravity Center of the Work    G =  mm
- Friction Coefficient of the Bearing    μ =
- Rated Rotational Speed of Servo Motor    N1 =  r/min
- Other User Condition

## Driving Pattern and Condition

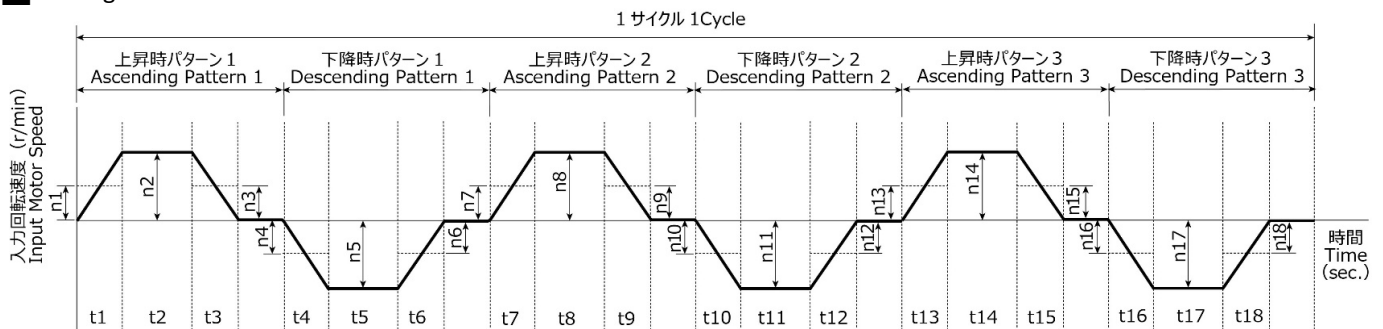

- Ascending Pattern 1
  - \* Gravity Center of the Work G = 0 mm, Please enter here.
  - Acceleration Time 1    t1 =  sec.
  - Constant Speed Time 1    t2 =  sec.
  - Deceleration Time 1    t3 =  sec.
  - Enter Rotational Speed (Acceleration) 1    n1 =  r/min (Enter Average Rotational Speed)
  - Enter Rotational Speed (Constant Speed) 1    n2 =  r/min
  - Enter Rotational Speed (Deceleration) 1    n3 =  r/min (Enter Average Rotational Speed)
- Descending Pattern 1
  - \* Not required for Gravity Center of the Work G = 0 mm
  - Acceleration Time 2    t4 =  sec.
  - Constant Speed Time 2    t5 =  sec.
  - Deceleration Time 2    t6 =  sec.
  - Enter Rotational Speed (Acceleration) 2    n4 =  r/min (Enter Average Rotational Speed)
  - Enter Rotational Speed (Constant Speed) 2    n5 =  r/min
  - Enter Rotational Speed (Deceleration) 2    n6 =  r/min (Enter Average Rotational Speed)

● Ascending Pattern 2

\* Gravity Center of the Work G = 0 mm , Please enter here.

Acceleration Time 3 t7 =  sec.  
 Constant Speed Time 3 t8 =  sec.  
 Deceleration Time 3 t9 =  sec.  
 Enter Rotational Speed (Acceleration) 3 n7 =  r/min (Enter Average Rotational Speed)  
 Enter Rotational Speed (Constant Speed) 3 n8 =  r/min  
 Enter Rotational Speed (Deceleration) 3 n9 =  r/min (Enter Average Rotational Speed)

● Descending Pattern 2

\* Not required for Gravity Center of the Work G = 0 mm

Acceleration Time 4 t10 =  sec.  
 Constant Speed Time 4 t11 =  sec.  
 Deceleration Time 4 t12 =  sec.  
 Enter Rotational Speed (Acceleration) 4 n10 =  r/min (Enter Average Rotational Speed)  
 Enter Rotational Speed (Constant Speed) 4 n11 =  r/min  
 Enter Rotational Speed (Deceleration) 4 n12 =  r/min (Enter Average Rotational Speed)

● Ascending Pattern 3

\* Gravity Center of the Work G = 0 mm , Please enter here.

Acceleration Time 5 t13 =  sec.  
 Constant Speed Time 5 t14 =  sec.  
 Deceleration Time 5 t15 =  sec.  
 Enter Rotational Speed (Acceleration) 5 n13 =  r/min (Enter Average Rotational Speed)  
 Enter Rotational Speed (Constant Speed) 5 n14 =  r/min  
 Enter Rotational Speed (Deceleration) 5 n15 =  r/min (Enter Average Rotational Speed)

● Descending Pattern 3

\* Not required for Gravity Center of the Work G = 0 mm

Acceleration Time 6 t16 =  sec.  
 Constant Speed Time 6 t17 =  sec.  
 Deceleration Time 6 t18 =  sec.  
 Enter Rotational Speed (Acceleration) 6 n16 =  r/min (Enter Average Rotational Speed)  
 Enter Rotational Speed (Constant Speed) 6 n17 =  r/min  
 Enter Rotational Speed (Deceleration) 6 n18 =  r/min (Enter Average Rotational Speed)

● Other Driving Pattern and Driving Condition

■ Planned Servo Motor to Use \* If you planned to use specific Sevo Motor, please write here. (Model, Series , Specification etc...)

■ Customer Information

CS center Technical Support Desk  
 E-mail : tech-cs@nissei-gtr.co.jp

Company Name	Address
Department	
Job Title	Phone Number
Name	FAX Number
	E-mail

Purpose of Selection  New Facility  Replacement  Change model  Others(                    )

Type of Industry  Conveyor  Food Processing Machine  Machine for Agriculture or Fisheries

Tooling Machine  Packaging Machine  Printing・Paper Converting Machine

Special Machine  Construction Machine  Electrical and Electric Equipment

Medical Equipment  Design Office  Trading Company  Others(                    )

**Notice** Please note that we may send you separate message after registering your information we have obtained through customer inquiries.  
 Please let us know anytime if you want us to delete your information from our system.